

# Animations

Adding animations to your PowerPoint slides can help to capture the attention of your audience and highlight key points in your content. They can also help to ensure a smooth transition between your topics.

When a new slide appears, your audience tries to read the slide. If you start talking immediately, they may miss your explanations! Adding some movements on your slides helps your audience to be aware and motivated to your presentation. However, using too many animations can be distracting so be careful.

## Applying Animations

1. Select the slide in which you wish to apply an animation
2. Select an object or placeholder on your slide
3. Select from one of the animations to apply to selected object

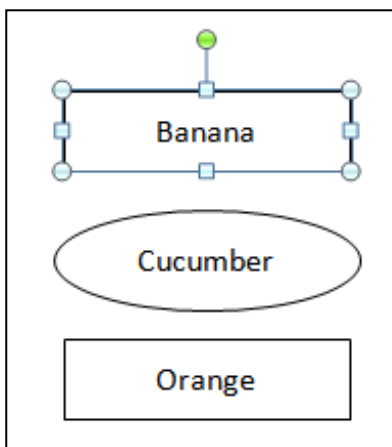

Click here for more animations

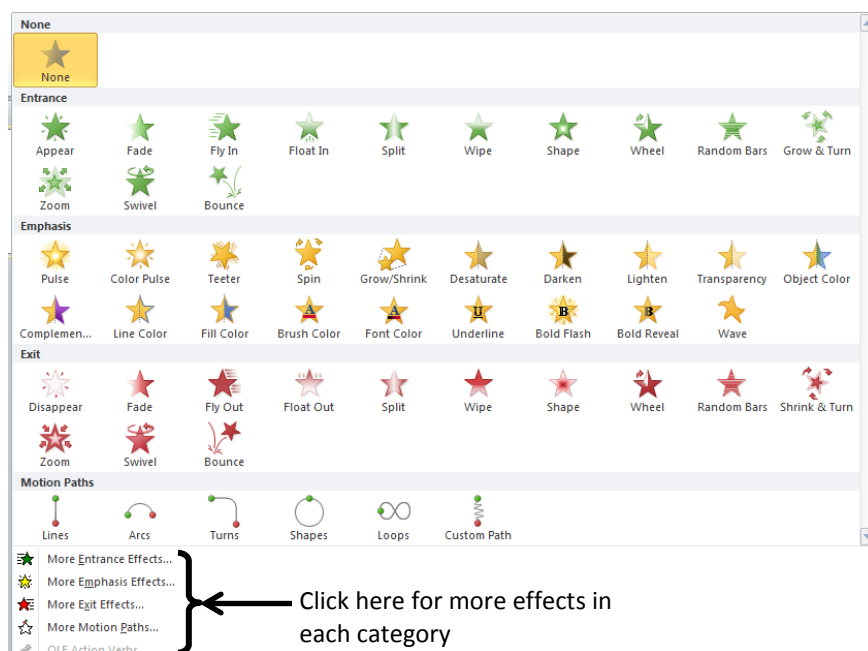

There are the four categories of animations.

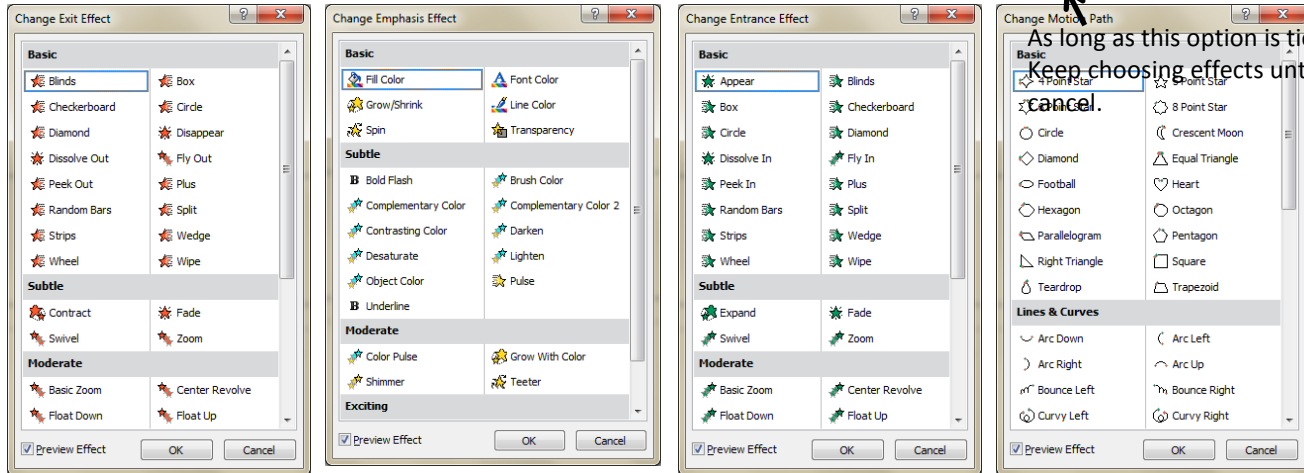

## Removing Animations

1. To remove an animation, select the object you wish to remove the animation from
2. Go to **Animations** and select **None**

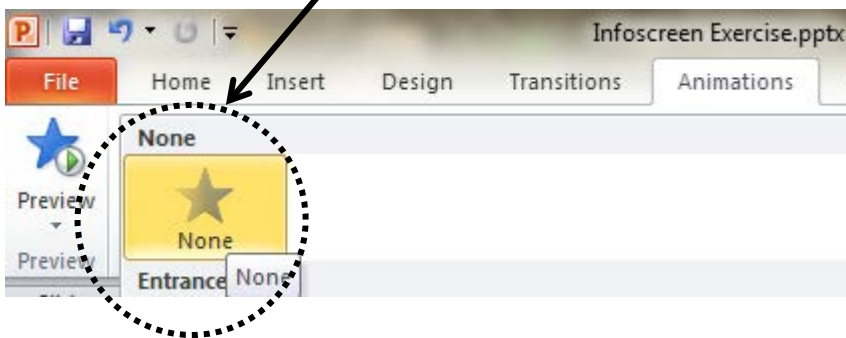

Repeat steps and create animations on your slides.

## Animation Pane

Click on the Animation Pane to see and overview of the slides animations



## Remove animations

1. Open the Animations Pane
2. Select the animation you want to remove and press the delete key on the keyboard  
or  
Right click on the animation and select remove

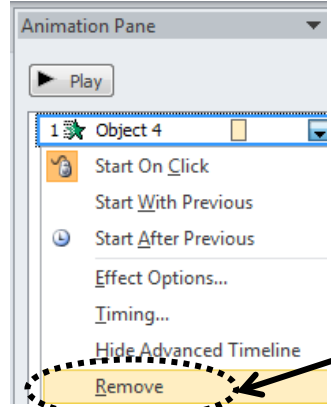
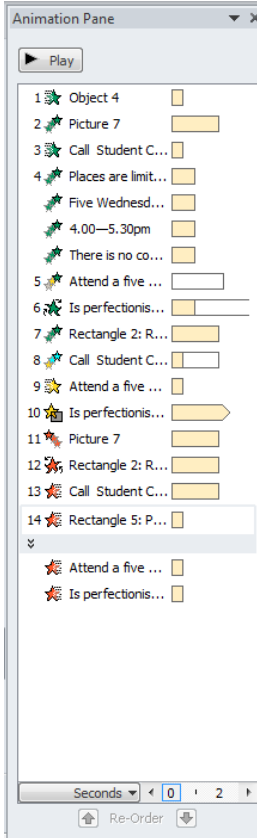

## Applying the same animation and effects to multiple objects/placeholders.

1. Select all objects/placeholders that you wish to customise the same

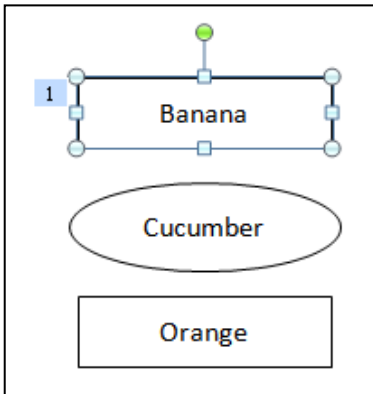

Tip: Selecting multiple objects

Hold down the **Ctrl** key and select each object you would like to apply the same animation to.

2. Apply custom animation

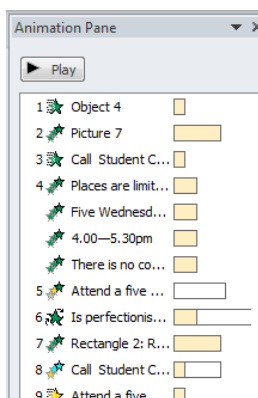
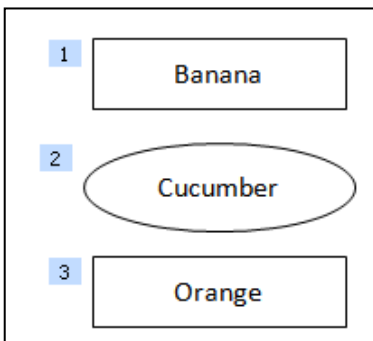

NOTICE: Animation order

The custom animation order number appears on both objects that you selected.

A star mark appears next to the slides that have animations and/or transitions applied.

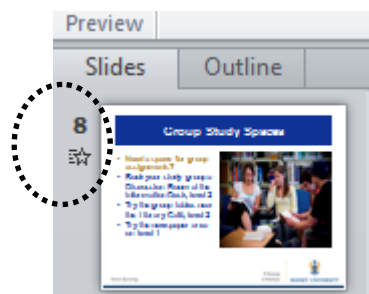

## Modifying animations

You may wish to change the type of effect after you apply animation. **Use the task pane**

1. Select the animation to be modified.

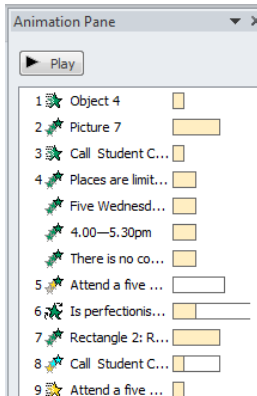

### NOTE:

You can **change the order** of effects by dragging them up or down the list

2. Select a different animation

